



# Flow Demo Board FS5 / FS7 / OOL

## Evaluation of flow sensors

### Suitable for gas and liquid flow sensors

#### Benefits & Characteristics

- Compatible with FS5/7 flow sensors
- Compatible with OOL flow sensors
- Constant Temperature Anemometer (CTA)
- Programmable temperature difference between heater and temperature sensor
- LED bar indicates current flow
- Analog Wheatstone Bridge (direct output)
- Protected with user replaceable fuse
- Output with zero flow offset subtraction

#### Illustration<sup>1)</sup>

Front side of Flow Demo Board:

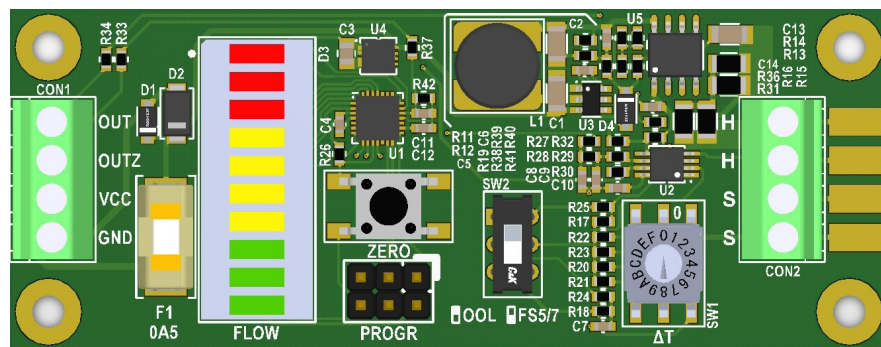

Back side of Flow Demo Board:

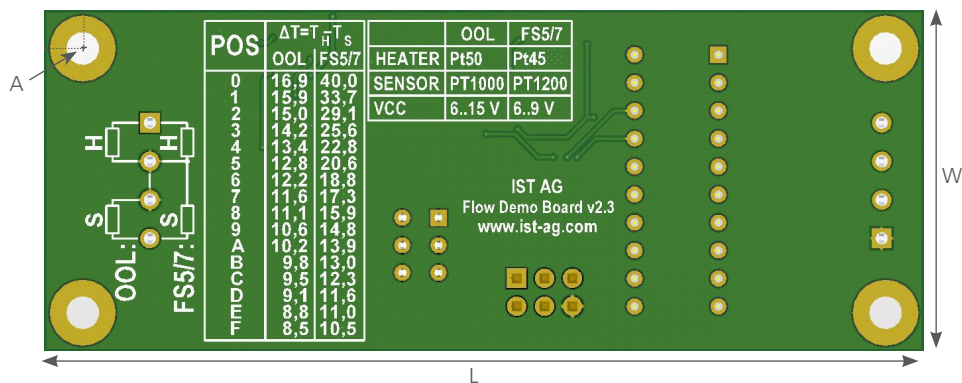

<sup>1)</sup> For actual size, see dimensions

#### Pin Assignment

GND:	Negative supply voltage	H:	Heater (inner = GND)
VCC:	Positive supply voltage	S:	Sensor (inner = GND)
OUT:	Output – Bridge's voltage		
OUTZ:	Output with zero flow offset subtraction		



## Technical Data

Dimensions (L x W x H in mm):	80 x 31 x 15; (A: 3.5 mm)
Operating temperature range:	-20 °C to +85 °C
Supply voltage for FS5/FS7 sensors:	6 to 9 V (typically 9 V)
Supply voltage for OOL sensors:	6 to 15 V (typically 12 V)
Supply current:	0.02 to 0.3 A
Maximum output voltage:	VCC - 2 V

## Product Photo

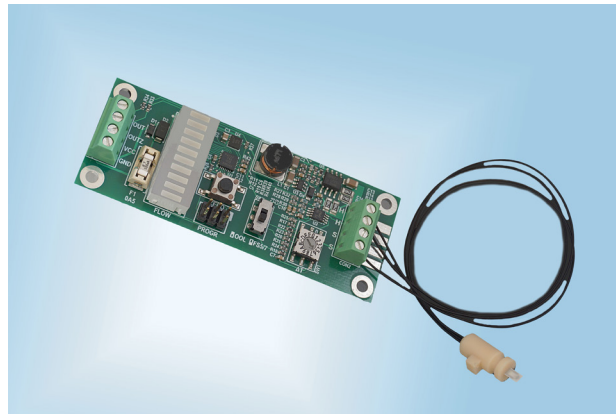

Board with FS sensor (example)

## Product Description

The IST AG Flow Demo Board is a universal board allowing the user to measure performance of IST AG gas and liquid flow sensors. It utilizes the Constant Temperature Anemometer principle using an analog Wheatstone Bridge. The Demo Board is designed to work with both FS5/7 and Out Of Liquid flow sensors. The user can easily program the temperature difference between heater and temperature sensor using a rotary switch and subtract zero flow offset from output voltage using OUTZ output and ZERO button. The sensor (FS5/7 or OOL) can be screwed to the PCB by using terminal blocks or directly soldered to the exposed pads of the PCB. Additionally, the user can limit power dissipated in the heater using supply voltage. The Flow Demo Board is not temperature-compensated.

Please read our Quick Start Guide for the Flow Demo Board before powering it. Applications:

- Gas flow meters
- Liquid flow meters
- Gas flow detectors
- Liquid flow detectors
- Liquids presence detectors